

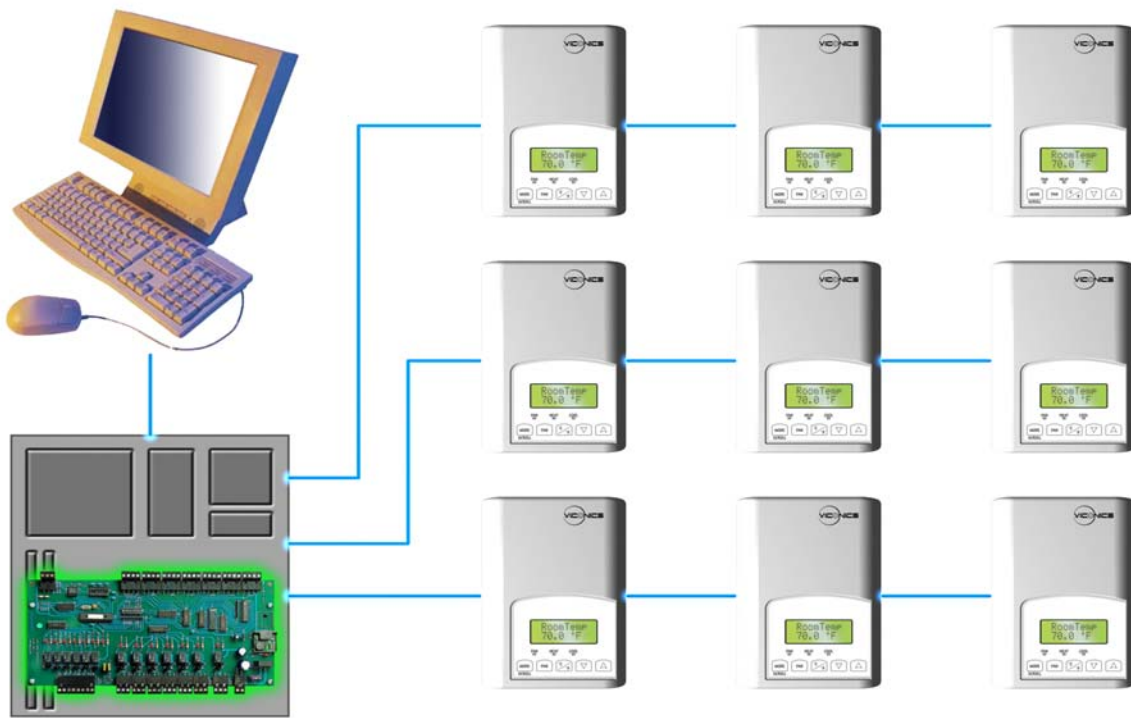

PIR Ready VT7200 Series 24 Vac Low Voltage Fan Coil Thermostats For Commercial and Lodging HVAC Applications

BACnet Integration Manual ITG-VT7200-BAC-E07

(028-6000 R7 Issue Date: February 25, 2008)



Product Overview

The VT7200 PI thermostat family is specifically designed for zoning applications. Typical applications include local hydronic reheat valve control and pressure dependent VAV with or without local reheat. The product features a backlit LCD display with dedicated function menu keys for simple operation. Accurate temperature control is achieved due to the product's PI proportional control algorithm, which virtually eliminates temperature offset associated with traditional, differential-based thermostats. Models are available for 3 point floating and analog 0 to 10 Vdc control. In addition remote room sensing is available.



They all contain an SPST auxiliary switch that can be used to control lighting or auxiliary reheat. 3 additional inputs are also provided for monitoring and / or various advanced functions.

All devices are also available with Echelon, BACnet MS-TP or Zigbee wireless network adapter.

The thermostats are also compatible with the new Viconics PIR cover accessories. Thermostats equipped with a PIR cover provide advanced active occupancy logic, which will automatically switch occupancy levels from Occupied to Stand-By and Unoccupied as required by local activity being present or not. This advanced occupancy functionality provides advantageous energy savings during occupied hours without sacrificing occupant comfort. All thermostats can be ordered with or without a factory installed PIR cover (see ordering notes below).

The additional following documents are available at: www.viconics.com

- Detailed information on the thermostat (VT7200X5x00(x), is available on document: *LIT-VT7200-PIR-Exx*.
- PIR application information and examples, are available on document: *APP-PIR-Guide-Exx*
- PIR cover installation information is available on document: *PIR Cover Installation-Exx*

Contents

Subject

- VT7200 series Protocol Implementation Conformance Statements (PICS)
 - Objects Table
- Standard Object Types Supported
- List of Proprietary Properties
- List of Property Value Range
- List of Property Enumeration Set for BV Objects and BI Objects
- List of Property Enumeration Set for MV Objects
- Integration - Global commands
- Integration - Graphic User Interface (GUI) Objects
- Integration - Configuration Objects
- Wiring Guide
 - Overview
 - Network Configuration
 - Maximum Number of Devices
 - Maximum Cable Length
 - EI-485 Repeaters
 - End Of Line Resistors
- Network Adapter
- Integrating Viconics' Device on an MSTP Network
- Default Device Name and Device ID
- Tips and Things You Need To Know
- Troubleshooting Section
- Document Control

VT7200 series Protocol Implementation Conformance Statement (PICS) _____

Vendor Name: Viconics Electronics Inc.

Product Name: VT7200 Thermostat Series

Product Model Number: VT7200C5000B and VT7200F5000B.

Product Description:

The VT7200 series BACnet communicating thermostat have been specifically designed for zoning applications to be monitored on a BACnet MS-TP® network.

Supported BACnet Services

The BACnet communicating thermostat meets all requirements for designation as an Application Specific Controller (B-ASC). The BACnet thermostat series supports the following BACnet Interoperability Building Blocks (BIBBs).

Application Service	Designation
Data Sharing – Read Property - B	DS-RP-B
Data Sharing – Read Property Multiple - B	DS-RPM-B
Data Sharing – Write Property - B	DS-WP-B
Device Management - Device Communication Control - B	DM-DCC-B
Device Management - Dynamic Device Binding - B	DM-DDB-B
Device Management - Dynamic Object Binding - B	DM-DOB-B

Note 1: The thermostat does not support segmented requests or responses.

Objects Table

Object Name	Type and Instance	Object Property	Thermostat Parameter	
VT7200x5000B	Device	Object_Identifier Property 75 (R,W)	Unique ID number of a device on a network	
		Object_Name Property 77 (R,W)	Unique name of a Device on a network	
		Model Name Property 70 (R)	Thermostat Model number	
		Firmware Revision Property 44 (R)	Current BACnet firmware revision used by the thermostat	
		Protocol Version Property 98 (R)	Current BACnet firmware protocol version Default is Version 1	
		Protocol Revision Property 139 (R)	Current BACnet firmware protocol revision Default is Version 2	
		Max ADPU Length Property 62 (R)	Maximum ADPU Length accepted Default is 244	
		ADPU Timeout Property 10 (R)	ADPU timeout value Default is 60 000 ms	
		Max_Master (R,W)	Maximum master devices allowed to be part of the network. 0 to 127, default is 127	
		MS/TP_Address Property 1001 (R,W)	BACnet MS-TP MAC Address. Proprietary attribute. Default is as assigned by configuration	
		MS/TP_Baud_Rate Property 1002 (R,W)	BACnet MS-TP Baud-Rate. Proprietary attribute. Range is: 1 = 9.6 KBps, 2 = 19.2 KBps, 3 = 38.4 KBps, 4 = 76.8 KBps and 5 = Auto Baud Rate. Index 5 is <i>Write only</i> . Reading attribute will state current Baud rate used. Writing index 1 to 4 will fix the Baud rate to the desired value.	
Object Name	Type and Instance	Object Property	VT7200C5000B	VT7200F5000B
Room Temperature	AV 7	Present_Value (R,W)	√	√
Room Temp Override	BV 8	Present_Value (R,W)	√	√
Outdoor Temperature	AV 9	Present_Value (R,W)	√	√
AUX Output	BV 49	Present_Value (R,W)	√	√
Sequence of Operation	MV 41	Present_Value (R,W)	√	√
System Mode	MV 14	Present_Value (R,W)	√	√
Occupancy Command	MV 13	Present_Value (R,W)	√	√

Object Name	Type and Instance	Object Property	Thermostat Parameter	
Object Name	Type and Instance	Object Property	VT7200C5000B	VT7200F5000B
Control Output	GRP 57	Present_Value (R)	√	√
PI Heating Demand	AV 58	Present_Value (R)	√	√
PI Cooling Demand	AV 59	Present_Value (R)	√	√
Supply Temperature	AI 12	Present_Value (R)	√	√
Controller Status	GRP 65	Present_Value (R)	√	√
AUX Status	BI 69	Present_Value (R)	√	√
Heating Valve Status	MV 70	Present_Value (R)	√	
Cooling Valve Status	MV 71	Present_Value (R)	√	
BI 1 Status	BI 66	Present_Value (R)	√	√
BI 2 Status	BI 67	Present_Value (R)	√	√
UI 3 Status	BI 68	Present_Value (R)	√	√
Local Motion	BI 73	Present_Value (R)	√	√
Effective Occupancy	MV 74	Present_Value (R)	√	√
Controller Alarms	GRP 61	Present_Value (R)	√	√
Window Alarm	BI 62	Present_Value (R)	√	√
Filter Alarm	BI 63	Present_Value (R)	√	√
Service Alarm	BI 64	Present_Value (R)	√	√
Temperature Setpoints	GRP 50	Present_Value (R)	√	√
Occupied Heat Setpoint	AV 51	Present_Value (R,W)	√	√
Occupied Cool Setpoint	AV 52	Present_Value (R,W)	√	√
Stand-by Heat Setpoint	AV 55	Present_Value (R,W)	√	√
Stand-by Cool Setpoint	AV 56	Present_Value (R,W)	√	√
Unoccupied Heat Setpoint	AV 53	Present_Value (R,W)	√	√
Unoccupied Cool Setpoint	AV 54	Present_Value (R,W)	√	√
Keypad Lockout	MV 42	Present_Value (R,W)	√	√

Object Name	Type and Instance	Object Property	Thermostat Parameter	
Object Name	Type and Instance	Object Property	VT7200C5000B	VT7200F5000B
General Options 1	GRP 16	Present_Value (R)	√	√
BI 1 Configuration	MV 17	Present_Value (R,W)	√	√
BI 2 Configuration	MV 18	Present_Value (R,W)	√	√
UI 3 configuration	MV 19	Present_Value (R,W)	√	√
Menu Scroll	BV 20	Present_Value (R,W)	√	√
Temperature Scale	BV 22	Present_Value (R,W)	√	√
Out#1 Config	MV 23	Present_Value (R,W)	√	√
AUX Configuration	MV 25	Present_Value (R,W)	√	√
General Options 2	GRP 26	Present_Value (R)	√	√
Heating Setpoint Limit	AV 28	Present_Value (R,W)	√	√
Cooling Setpoint Limit	AV 29	Present_Value (R,W)	√	√
Setpoint Type	BV 30	Present_Value (R,W)	√	√
Temporary Occupancy Time	MV 31	Present_Value (R,W)	√	√
Deadband	AV 32	Present_Value (R,W)	√	√
Reheat Time Base	BV 33	Present_Value (R,W)	√	√
Stand-by Time	AV 34	Present_Value (R,W)	√	√
Unoccupied Time	AV 35	Present_Value (R,W)	√	√
Output Options	GRP 36	Present_Value (R)	√	√
Control type	BV 37	Present_Value (R,W)	√	
Floating Motor timing	MV 38	Present_Value (R,W)	√	
On Off Control CPH	MV 39	Present_Value (R,W)	√	
Direct Reverse Acting	BV 40	Present_Value (R,W)		√

Standard Object Types Supported

Object Type	Supported Objects	Dynamically Creatable	Dynamically Deletable	Optional Properties Supported	Writable Properties
Analog Input	<input checked="" type="checkbox"/>	<input type="checkbox"/>	<input type="checkbox"/>	Reliability	Out_of_Service
Analog Value	<input checked="" type="checkbox"/>	<input type="checkbox"/>	<input type="checkbox"/>	Reliability	Present_Value ^{a,b} Out_of_Service ^a Object_Name ^c
Binary Input	<input checked="" type="checkbox"/>	<input type="checkbox"/>	<input type="checkbox"/>	Reliability Active_Text Inactive_Text	Out_of_Service
Binary Value	<input checked="" type="checkbox"/>	<input type="checkbox"/>	<input type="checkbox"/>	Reliability Active_Text Inactive_Text	Present_Value Out_of_Service
Device	<input checked="" type="checkbox"/>	<input type="checkbox"/>	<input type="checkbox"/>	Max_Master Max_Info_frames	Object_Identifier Object_name Max_Master
Group	<input checked="" type="checkbox"/>	<input type="checkbox"/>	<input type="checkbox"/>	N/A	N/A
Multi-state Value	<input checked="" type="checkbox"/>	<input type="checkbox"/>	<input type="checkbox"/>	Reliability States_Text	Present_Value ^d Out_of_Service ^d

a : Present_Value and Out_of_Service properties are writable for every AV objects except :

- PI Heating Demand (AV54)
- PI Cooling Demand (AV55)

b : Present_Value property for Room Temperature (AV7) and Room Humidity (AV10) is writable only if Room Temp Override (BV8) is enabled and Room Humidity Override (BV11) is enabled respectively.

c : Object_Name property is writable for the following object only :

- Room Temperature (AV7)

d : Present_Value and Out_of_Service properties are writable for every MV objects except :

- Heating Valve Status (MV66)
- Cooling Valve Status (MV67)
- Fan Status (MV68)

List of Proprietary Properties

Property name	ID	BACnet Data type	Description
Major_Version	1000	CharacterString	The version number of the BACnet communications module. This is the hardware version number
MS/TP_Address	1001	Unsigned	Display the MAC layer address of the module
MS/TP_Baud_Rate	1002	Unsigned	Display the communication baud rate of the module
Sensor_Offset	1005	REAL	Display the temperature or humidity calibration value. The range is -5.0 deg F to 5.0 deg F for a temperature and -15% to 15% for humidity.

List of Property Value Range Restrictions

Object name	Object Type and instance	Under range value	Over range value	Default value
Supply Temperature	AI 12	-39.9°F (-40°C)	121.9°F (50°C)	N/A
Room Temperature	AV 7	-39.9°F (-40°C)	121.9°F (50°C)	N/A
Outdoor Temperature	AV 9	-39°F (-40°C)	121.9°F (50°C)	N/A
Heating Setpoint Limit	AV 27	40°F (4.5°C)	90°F (32°C)	90°F (32°C)
Cooling Setpoint Limit	AV 28	54°F (12°C)	100°F (37.5°C)	54°F (12°C)
Deadband	AV 32	2°F (1°C)	5°F (2.5°C)	2°F (1°C)
Occupied Heat Setpoint	AV 51	40°F (4.5°C)	90°F (32°C)	72°F (22°C)
Occupied Cool Setpoint	AV 52	54°F (12°C)	100°F (37.5°C)	74°F (24°C)
Unoccupied Heat Setpoint	AV 53	40°F (4.5°C)	90°F (32°C)	62°F (16.5°C)
Unoccupied Cool Setpoint	AV 54	54°F (12°C)	100°F (37.5°C)	80°F (26.5°C)
PI Heating demand	AV 58	0%	100%	0%
PI Cooling demand	AV 59	0%	100%	0%
Stand-by Time	AV 34	0.5 Hours	24.0 Hours	0.5 Hours
Unoccupied Time	AV 35	0.0 Hours	24.0 Hours	0.0 Hours
Stand-by Heat Setpoint	AV 55	40°F (4.5°C)	90°F (32°C)	72°F (22°C)
Stand-by Cool Setpoint	AV 56	54°F (12°C)	100°F (37.5°C)	74°F (24°C)

List of Property Enumeration Sets for BV Objects and BI Objects

Object Name	Object Type and instance	Inactive_Text	Active_Text	Default value
Room Temp Override	BV 8	Normal	Override	Normal
Menu Scroll	BV 20	No Scroll	Scroll Active	Scroll Active
Auto Mode Enable	BV 21	Disabled	Enabled	Disabled
Temperature Scale	BV 22	°C	°F	°F
Setpoint Type	BV 30	Permanent	Temporary	Permanent
Reheat Time Base	BV 33	15 minutes	10 seconds	15 minutes
Control Type	BV 37	On/Off	Floating	On/Off
Direct/ Reverse Acting	BV 40	Direct Acting	Reverse Acting	Direct Acting
AUX Out	BV 49	Off	On	Off
Window Alarm	BI 62	Off	On	Off
Filter Alarm	BI 63	Off	On	Off
Service Alarm	BI 64	Off	On	Off
BI 1 Status	BI 66	Deactivated	Activated	Deactivated
BI 2 Status	BI 67	Deactivated	Activated	Deactivated
UI 3 Status(*)	BI 68	Deactivated	Activated	Deactivated
Aux Status	BI 69	Off	On	Off
Local Motion	BI 73	No Motion	Motion	No Motion

(*) This object will be linked to the value of the 'UI 3 Configuration' object.
 When the 'UI 3 Configuration' object value is 0, 3 or 4, the value will be set to 'Deactivated'

List of Property Enumeration Sets for MV Objects

Object Name	Object ID	BACnet Index	Text	Default value
Occupancy Command	MV 13	1	Local Occupancy	Depends on network command
		2	Occupied	
		3	Unoccupied	
System Mode Note 1	MV 14	1	Off	Note 2
		2	Auto	
		3	Cool	
		4	Heat	
BI1 Configuration	MV 17	1	None	None
		2	Rem NSB	
		3	Motion NO	
		4	Motion NC	
		5	Window	
BI2 Configuration	MV 18	1	None	None
		2	Door Dry	
		3	Override	
		4	Filter	
		5	Service	
UI3 Configuration	MV 19	1	None	None
		2	COC/NH	
		3	COC/NC	
		4	COS	
		5	SS	

Note 1 Enumeration sets for MV14 depends on Sequence of Operation (MV41) value upon device discovery. If required enumeration is not present, set MV41 to desired value and rediscover MV14 object. Available enumeration will now reflect required configuration.

Note 2 Default value depends on MV39 value upon device discovery

MV39 Index	Function	Default Value
1	Cooling Only	Cool
2	Cooling with Reheat	Heat
3	Heating Only	Heat
4	Heating with Reheat	Heat
5	Cooling/Heating 4 Pipes	Heat
6	Cooling/Heating 4 Pipes with Reheat	Heat

Object Name	Object ID	BACnet Index	Text	Default value
Out#1 Config	MV 23	1	One Output	One Output
		2	Separate Outputs	
AUX Configuration	MV 25	1	Not used	Not Used
		2	NO with Occ	
		3	NC with Occ	
		4	NO with Occ & Fan	
		5	NC with Occ & Fan	
		6	Network controlled	

Object Name	Object ID	BACnet Index	Text	Default value
Temporary Occupancy Time	MV 31	1	0 hour	2 hours
		2	1 hour	
		3	2 hours	
		4	3 hours	
		5	4 hours	
		6	5 hours	
		7	6 hours	
		8	7 hours	
		9	8 hours	
		10	9 hours	
		11	10 hours	
		12	11 hours	
		13	12 hours	
		14	13 hours	
		15	14 hours	
		16	15 hours	
		17	16 hours	
		18	17 hours	
		19	18 hours	
		20	19 hours	
		21	20 hours	
		22	21 hours	
		23	22 hours	
		24	23 hours	
		25	24 hours	
Floating Motor Timing	MV 38	1	0.5 minute	1.5 minutes
		2	1 minute	
		3	1.5 minutes	
		4	2 minutes	
		5	2.5 minutes	
		6	3 minutes	
		7	3.5 minutes	
		8	4 minutes	
		9	4.5 minutes	
		10	5 minutes	
		11	5.5 minutes	
		12	6 minutes	
		13	6.5 minutes	
		14	7 minutes	
		15	7.5 minutes	
		16	8 minutes	
		17	8.5 minutes	
		18	9 minutes	
On-Off Control CPH	MV 39	1	3 CPH	4 CPH
		2	4 CPH	
		3	5 CPH	
		4	6 CPH	
		5	7 CPH	
		6	8 CPH	

Object Name	Object ID	BACnet Index	Text	Default value
Sequence of Operation	MV 41	1	Cooling Only	Heating Only
		2	Heating Only	
		3	Cooling & Reheat	
		4	Heating & Reheat	
		5	Cool/Heat4P Note 7	
		6	Cool/Heat4P&Reht Note 7	
Keypad Lockout	MV 42	1	Level 0	Level 0
		2	Level 1	
		3	Level 2 (Not Used)	
		4	Level 3 (Not Used)	
		5	Level 4	
		6	Level 5	
Heating Valve Status Note 8	MV 70	Note 9	Note 9	Note 9
Cooling Valve Status Note 10	MV 71	Note 11	Note 11	Note 11
Effective Occupancy	MV 74	1	Occupied	Depends on local occupancy
		2	Unoccupied	
		3	Temporary Occupied	
		4	Stand-by	

Note 7 Indexes number 5 (Cool/Heat4P) and number 6 (Cool/Heat4P&Reht) are not present in the Sequence of Operation object (MV41) for the following model : VT7300M1000B

Note 8 Enumeration sets for MV70 depends on Control Type (BV37) value and Out1Conf (MV23) value upon device discovery. If required enumeration is not present, set BV37 and MV23 to desired value and rediscover MV70 object. Available enumeration will now reflect required configuration.

Note 9 Available object name, state text and default value depends on Control Type (BV37) value and Out#1 Conf (MV23) upon device discovery.

BV37 Value	MV23 Index	MV70 Object Name	Function MV70 State Text Index	Default Value
On/Off	1 One Output	Unused Output	N/A	N/A
	2 Separate Outputs	Heating Valve Status	1 Closed – 2 Open	Closed
Floating	1 One Output	Unused Output	N/A	N/A
	2 Separate Outputs	Heating Valve Status	1 Stopped - 2 Opening - 3 Closing	Stopped

Note 10 Enumeration sets for MV71 depends on Control Type (BV37) value and Out1Cong (MV23) value upon device discovery. If required enumeration is not present, set BV37 and MV23 to desired value and rediscover MV71 object. Available enumeration will now reflect required configuration.

Note 11 Available object name, state text and default value depends on Control Type (BV37) value and Out#1 Conf (MV23) upon device discovery.

BV37 Value	MV23 Index	MV71 Object Name	Function MV71 State Text Index	Default Value
On/Off	1 One Output	Heat/Cool Valve Status	1 Closed – 2 Open	Closed
	2 Separate Outputs	Cooling Valve Status	1 Closed – 2 Open	Closed
Floating	1 One Output	Heat/Cool Valve Status	1 Stopped - 2 Opening - 3 Closing	Stopped
	2 Separate Outputs	Cooling Valve Status	1 Stopped - 2 Opening - 3 Closing	Stopped

Integration – Global Commands

The following figure shows which objects from the thermostat can be monitored and commanded from the BAS front-end.

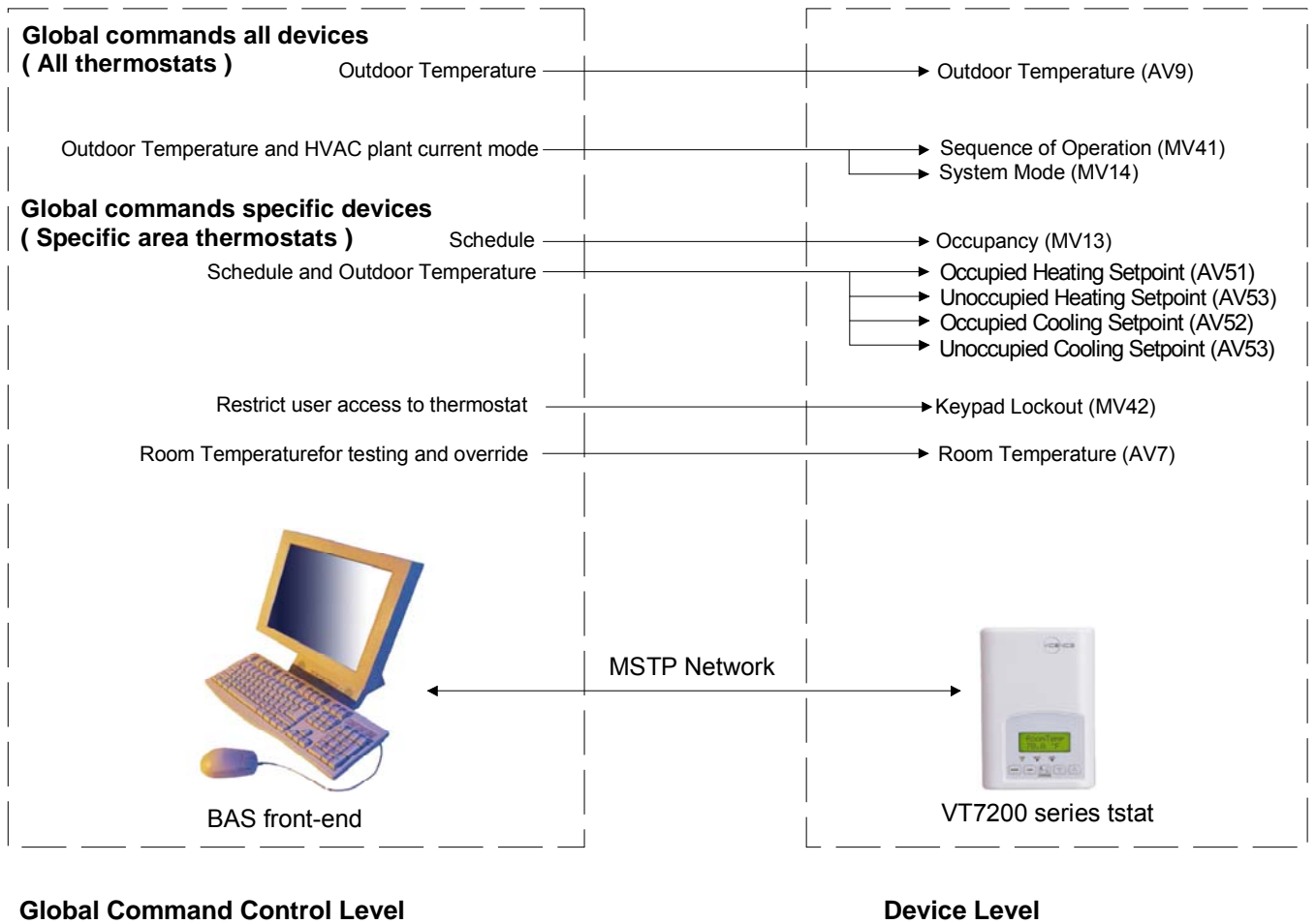
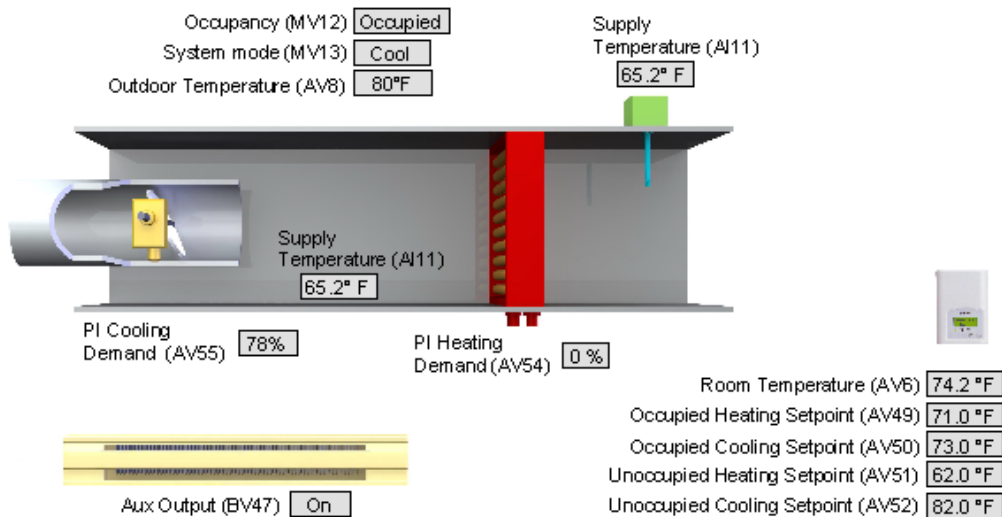

Figure 1: Global commands from a BAS front-end to a VT7200 series thermostat

Integration – Graphic User Interface (GUI) objects

The following objects should be typically used in a GUI:

- Room Temperature (AV7);
- Occupied and Unoccupied Heat Setpoints (AV 51 and AV53);
- Occupied and Unoccupied Cool Setpoints (AV 52 and AV54);
- Outdoor Temperature (AV 9);
- Supply Temperature (AI12) (If available);
- Occupancy (MV13);
- System Mode (MV14);
- Heating Valve Status (MV70);
- Cooling Valve Status (MV71);
- PI Heating Demand (AV58)
- PI Cooling Demand (AV59)
- Window Alarm (BI 62);
- Filter Alarm (BI 63);
- Service Alarm (BI 64);



Configuration Objects

The following objects and group objects should be typically used for configuration purposes:

- General Options 1 Group GRP 16 and its complete list of objects;
- General Options 2 Group GRP 26 and its complete list of objects;
- Output Options Group GRP 36 and its complete list of objects.

If your BAS allows you to remove objects, Viconics recommends removing all configuration objects once your setup is complete. This will prevent unnecessary network polling and traffic.

Wiring guide

Overview

Viconics uses EIA-485 as the physical layer between their devices and supervisory controllers. For clarity we will use the term “Device” to represent any product with an active EIA-485 network connection, including Viconics and non-Viconics controllers.

Summary Specifications:

Parameter	Details
Media	Twisted pair 22AWG-24 AWG, shielded recommended
Characteristic Impedance	100-130 ohms
Distributed capacitance	Less than 100 pF per meter (30 pF per foot)
Maximum length per segment	1200 meters (4000 feet) Note: AWG 18 cable
Polarity	Polarity sensitive
Multi-drop	Daisy-chain (no T connections)
Terminations	<ol style="list-style-type: none">1. Viconics’ devices are installed at both ends of the MSTP network: 120 Ohms resistor should be installed at each end.2. A Viconics device is installed at one end of the MSTP network and a 3rd party device is installed at the other end: Install an End-Of-Line resistor value that matches the 3rd party device instruction regarding the End-Of-Line resistors3. 3rd party devices are installed at both ends of the MSTP network: Follow the 3rd party device instructions regarding the End-Of-Line resistors.
Network Bias Resistors	510 ohms per wire (max. of two sets per segment)
Maximum number of nodes per segment	64 (Viconics devices only)
Maximum number of nodes per network	128
Baud rate	9600, 19200, 38400, 76800 (Auto detect)

Table 1: Summary of Specifications for a Viconics’ EIA-485 Network

Cable Type

Viconics recommends the use of balanced 22-24 AWG twisted pair with a characteristic impedance of 100-120 ohms, capacitance of 17 pF/ft or lower, with a braided shield.

Impedance

A value based on the inherent conductance, resistance, capacitance and inductance that represent the impedance of an infinitely long cable. The nominal impedance of the cable should be between 100Ω and 120Ω. However using 120Ω will result in a lighter load on the network.

Capacitance (pF/ft)

The amount of equivalent capacitive load of the cable, typically listed in a per foot basis. One of the factors limiting total cable length is the capacitive load. Systems with long lengths benefit from using low capacitance cable (i.e. 17pF/ft or lower).

Network Configuration

EIA-485 networks use a daisy chain configuration. A daisy chain means that there is only one main cable and every network device is connected directly along its path.

Figure 3 illustrates two improper network configurations and the proper daisy chain configuration.

Other methods of wiring an EIA-485 network may give unreliable and unpredictable results. There are no troubleshooting methods for these types of networks. Therefore, a great deal of site experimentation may have to be done, making this a difficult task with no guarantee of success. Viconics will only support daisy chain configurations.

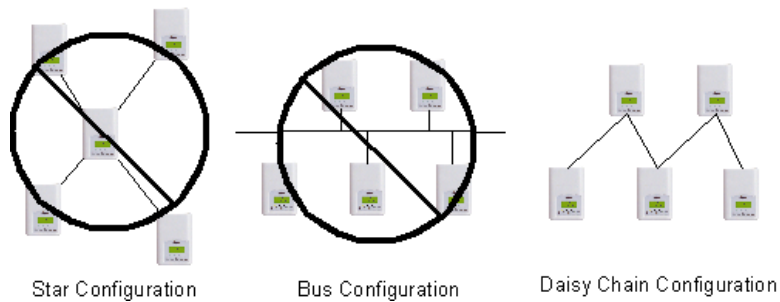

Figure 3: Three different network configurations: star, bus, and daisy chain. Only the daisy chain configuration is correct for an EIA-485 network.

Maximum Number of Devices

A maximum of 64 nodes is allowed on a single daisy chain segment. A node is defined as any device (Panel, Zone, Repeater, etc) connected to the RS485 network. Terminators do not count as a node.

To determine the number of nodes on a network, add the following:

- One node for each device, including main panels
- One node for each repeater on the chain

For the example in Figure 4, we have one node for the main Panel, plus 4 for the controllers, for a total of 5 nodes.

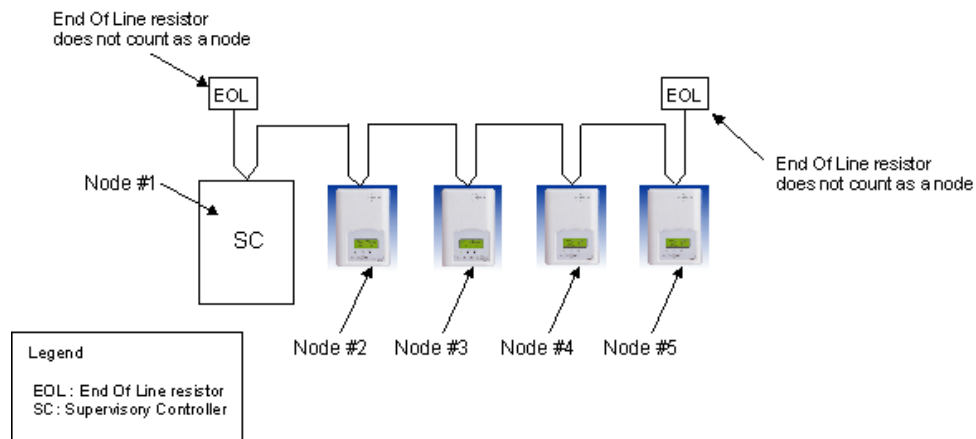

Figure 4: Five nodes network example.

If you have more than 64 devices, then repeaters are required to extend the network.

Maximum Cable Length

The maximum length of a chain is related to its transmission speed. The longer the chain, the slower the speed. Using proper cable, the maximum length of an EIA-485 daisy chain is 4000-ft (1200 m). This will only work reliably for data rates up to 100,000 bps. Viconics' maximum data rate is 76,800 bps.

If you require a maximum network length of more than 4000 feet, then repeaters are required to extend the network.

EIA-485 Repeaters

If you have more than 64 devices, or require a maximum network length of more than 4000 feet, then repeaters are required to extend the network. The best configuration is to daisy chain the repeaters to the main panel. From each of these repeaters, a separate daisy chain will branch off. Figure 5 demonstrates a valid use of repeaters in an EIA-485 network.

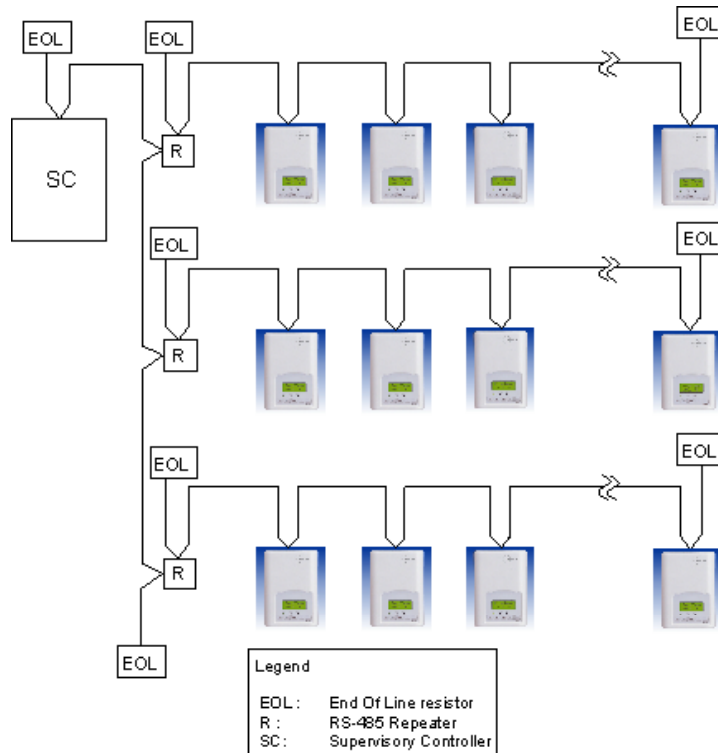

Figure 5: Correct usage – repeaters are daisy chained to the supervisory controller and separate daisy chains branch from each repeater.

Do not install repeaters in series, as this may result in network reliability problems. Figure 6 demonstrates an incorrect use of a repeater in an EIA-485 network.

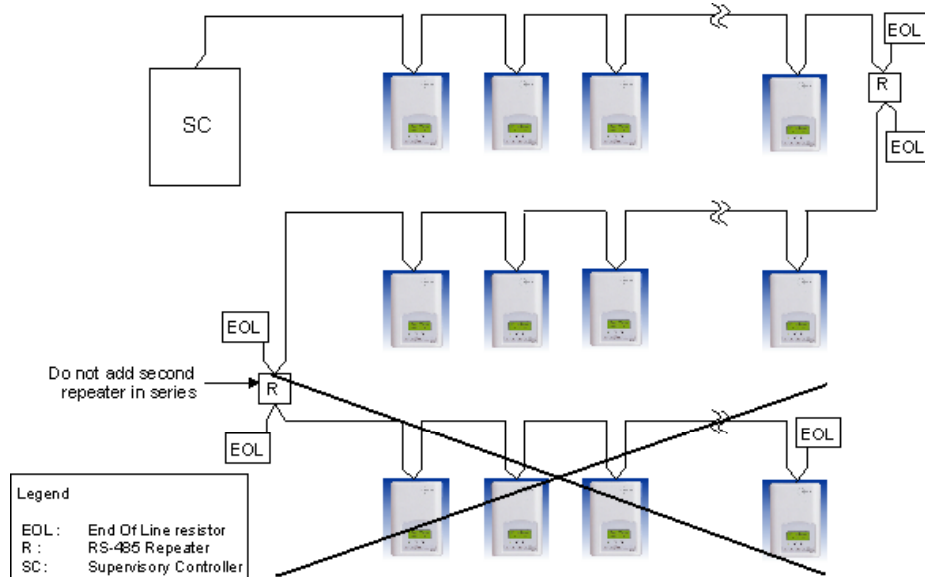

Figure 6: Incorrect usage – the second repeater in series may result in an unreliable system

End Of Line (EOL) Resistors

MS/TP network must be properly terminated. For daisy chain configurations, you must install an EOL resistor at each end of the daisy chain. Depending on your MSTP network configuration, the resistance value of the EOL resistor may change:

- **Viconics' devices are installed at both ends of the MSTP network:**
120 Ohms resistor should be installed at each end.
- **A Viconics device is installed at one end of the MSTP network and a 3rd party device is installed at the other end:**
Install an End-Of-Line resistor value that matches the 3rd party devices instructions regarding its EOL resistor value;
- **3rd party devices are installed at both ends of the MSTP network:**
Follow the 3rd party devices instructions regarding its EOL resistor value.

Network Adapter

The polarity of the connection to the cable is important. From one module to the other it is important that the same colored wire be connected to "plus" or "+" and the other colored wire be connected to the "minus" or "-". Figures 7 shows the proper MS/TP connections and the location of the Status LED. This Status LED may help to troubleshoot network problems.

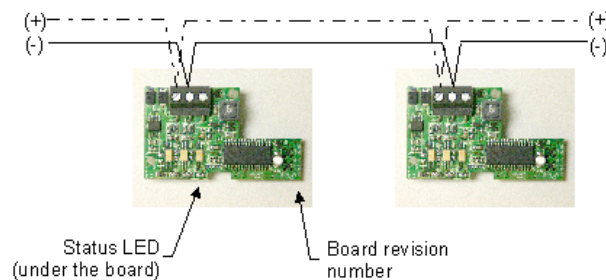

Figure 7: Correct MS/TP connections and location of a Status LED on a BACnet module

IMPORTANT NOTE: The Ref terminal should **NEVER** be used to wire shields. The 2 shields from each feed of the network connection to a thermostat should be wired together in the back of the thermostat and properly protected to prevent any accidental connection to the ground.

The joined shield connection should then be grounded at a **SINGLE** point on the whole segment. More than one ground connection to a shielded wire may induce ground loop noises and affect communication.

Table 2 shows the different possibilities with the Status LED behaviour of the BACnet module.

Condition of the Status LED	Possible Cause	Solution
➤ 1 short blink	A T7600 BACnet module has been installed on a VT7200 thermostat	Install a VT7200 BACnet module on the thermostat
	A VT7200 module has been installed on a T7600 thermostat	Install the BACnet module on a VT7200 thermostat model
➤ 2 short blink (no wires connected to the module)	The right module has been installed on the right thermostat model	N/A
➤ 2 short blink (wires connected to the module)	Module is not at the same baud rate as the network	Power off and on the thermostat
➤ 2 short blinks and a longer blink (wires connected to the module)	The module has detected the presence of a network	N/A
➤ Right after power is applied: 2 long blinks and then no blinking	Polarity has been reversed at the module	Reverse polarity at the module

Table 2: Status LED condition and possible solutions

Default Device Name and default Device ID

Default **Device Name** is set to: Model number – MAC:

- Where MAC is the current MAC address of the device.
- Where Model number is Viconics part number.

The device name will be upgraded as soon as there is a change to the device MAC address.

Default **Device ID** is set to: 72000 + MAC

- Where MAC is the current MAC address of the device.

The device ID will also be upgraded as soon as there is a change to the device's MAC.

For example, when a VT7200C5000B thermostat with a MAC address of 63 is connected to a network, its default Device Name will be VT7200C5000B-63 and its default Device ID will be 72063.

Device Name and Device ID properties are writable in Viconics' device object. Both properties can be renamed from any BACnet network management tool as long as the tool itself can write to these properties.

Integrating Viconics' Devices on an MSTP Network

Before doing any BACnet integration, make sure to have Viconics' PICS (Protocol Implementation Conformance Statement).

This PICS document lists all the BACnet Services and Object types supported by a device and can be found at www.viconics.com.

Viconics' devices do not support the COV service. COV reporting allows an object to send out notices when its Present-Value property is incremented by a pre-defined value. Since this is not supported at Viconics' end, special attention should be given to the polling time settings at the Supervisory Controller and Workstation level when using a graphic interface or an application program to read or write to a Viconics' object.

Graphical interfaces

For example, some graphic interface might poll every data linked to the graphic page on a COV basis. If the 3rd party device does not support COV, the graphic interface then relies on a pre-configured polling interval, which is usually in hundredths of milliseconds. Any device containing a monitored object could be subject to network traffic congestion if such a polling interval is used. Viconics strongly recommend a polling interval of 5 seconds minimum for any graphic interface. This becomes even more critical in area graphics where a single representation might poll many devices. If proper poll rate is not respected, devices may be reported offline by certain front end by saturating the traffic handling capacity of BACnet MSTP without COV subscription.

Free programmed object or loops

As for the application program, you might want to read and write any MSTP data on an "If Once" basis or a "Do Every" loop basis instead of reading or writing to a 3rd party device's object directly in the program. Otherwise, any read or write request will occur at the Supervisory Controller's program scan rate, which might as well be in hundredths of milliseconds. This can easily bog down a network as single commands can be sent to all ASC devices down the MSTP trunks every hundredth of milliseconds

Programs writing to the devices should have a structure similar to the following:

```
If Once Schedule = On then
  MV11 = Occupied
End If
If Once Schedule = Off Then          OR
  MV13 = Unoccupied
End If
Do Every 5min
  If Schedule = On Then
    MV11= Occupied
  Else
    MV13 = Unoccupied
  End If
End Do
```

Retries and Timeouts

Another thing to look for in a BACnet integration is the Device object of the Supervisory Controller (and the Operator's Workstation). This object contains the 2 following required properties:

- 1) Retry Timeout;
- 2) Number of APDU Retries;

1) The Retry Timeout property specifies the time between re-transmissions if the acknowledgement has not been received. When you are experiencing problems with controllers dropping off-line, increasing this value may help.

2) The Number of APDU Retries property specifies the number of times unsuccessful transmissions will be repeated. If the receiving controller has not received the transmission successfully after this many attempts, no further attempts will be made.

For example, if one of the thermostats does not reply to a Supervisory Controller (SC) request, and the SC's Retry Timeout is set to 2000 msec and the Number of APDU Retries is set to 1 (still at the SC level), then the SC will send one other request, 2 sec later. If the MSTP device does not reply, it will be considered Off-line by the workstation.

So having a Retry Timeout value of 10000 msec and a Number of APDU Retries property set to 3 at the SC level may prevent device from dropping Off-line. These properties should also be changed at the Workstation level since the workstation will likely issue requests to any MSTP devices when the graphics are used.

Tips and Things You Need To Know

- After the initial configuration of your device and if your BAS allows you to remove objects, we suggest that you remove all the configuration objects to prevent unnecessary polling of non used objects and to help speed up the network.
- All configuration objects are available and accessible locally from the device itself using the local configuration routine. Please refer to the Technical Manual LIT-VT7200-PIR-Exx for details.
- In its default mode of operation, the device will automatically match its baud rate to the baud rate of the network. Automatic baud rate detection will occur when the MS/TP communication port is initialized (on power up). If the network speed is changed, the device will keep listening at the previously detected speed for 10 minutes before resuming auto-bauding. Re-powering the devices will force right away auto-bauding.
- Enumeration sets for MV14 depends on Sequence of Operation (MV41) value upon device discovery. If required enumerations are not present, set MV41 to desired value and rediscover MV14 object. Available enumeration will now reflect required configuration.
- Enumeration sets for MV70 and MV71 depend on Control Type (BV37) value and Pipe Number (MV23) value upon device discovery. If required enumeration is not present, set BV37 and MV23 to desired value and rediscover MV70 and BV71 object. Available enumeration will now reflect required configuration.
- If the device should go off-line, the following binded thermostat parameters will be released:
 - Room Temperature
 - Outdoor Temperature
 - Occupancy
- The BACnet Data Link layer has two key parameters: the device object name and the device object ID. The device object name must be unique from any other BACnet device object name on the BACnet network (i.e. not just the MS/TP sub-network). The device object ID must be unique from any other BACnet device object ID on the entire BACnet network (i.e. not just the MS/TP sub-network).
- To assign manually a Room Temperature (AV7) value, users must first enable the Override mode in the Room Temp Override (BV8) object.
- Levels 2 and 3 of the Keypad Lockout object (MV42) are not used. If a user selects one of these 2 levels, the thermostat will discard it.
- Device Name and Device ID properties are writable in Viconics' device object. Both properties can be renamed from any BACnet network management tool as long as the tool itself give access to write to these properties.

Troubleshooting Section

Error / Trouble Condition	Possible Cause	Solution
Thermostat does not come online	Two or more controllers have the same MAC address.	Modify each duplicate address to a unique number.
	The MS/TP network has too many devices.	Do not exceed the maximum number of devices and maximum length allowed by the EIA-485 specifications.
	Too many devices were installed without any repeaters.	Repeaters need to be installed as specified in this document.
	The MS/TP cable runs are broken	Locate the break and correct wiring
	MS/TP connections at the module were reversed	Respect polarity of the wires on a MS/TP network.
	The thermostat does not have power	Apply power to the thermostat

Document Control

Document Name: ITG-VT7200-BAC-E05
 Document Filename: 028-6000_R5_ITG-VT7200-BAC-E05.doc

Revision	Date	Changes
01	January 4, 2006	Created to coincide with release of the VT7300 as a BTL listed product.
02	April 20, 2006	End of line resistors precisions and removed any Application Guide notes
03	July 18, 2006	Removed the DO1 to DO8 objects and the GRP69 object
04	October 23, 2006	Added a note regarding the Device Name and Device ID writable properties
05	January 18, 2007	Added the "Integrating Viconics' Devices on an MSTP Network" section